



**AC Semiconductor Motor Controller frenopact-2 S25..
Instructions**

MODE OF OPERATION

Ramp up potentiometer:

The motor starting time in a direct-on-line start depends on the characteristics of the motor load; the ramp up time must be longer than this time period so that the bypass relays are activated after the starting current has dropped to a steady level.

Ramp down potentiometer:

The motor stopping time may be extended by gradually reducing the voltage over the ramp down time.

The actual time taken to start and stop the motor will vary according to the combinations of above settings and the type of motor load itself.

Initial Torque potentiometer:

This adjusts the starting voltage and must be set to enable the motor to start rapidly. The soft start is a result of both initial torque and ramp up time adjustments.



ATTENTION!

- 1.To prevent electrical shock, disconnect from power source before installing or servicing.
- 2.The bypass relays in the main circuit may be in an undefined switching state due to handling during shipping. It is recommended to make the first cycle with the motor disconnected, to set the bypass relays to a defined switching state. If not performed, this may cause unexpected operation of the motor.
3. The frenopact-2 has been designed as Class A equipment. Use of the product in domestic environments can cause radio interference.
- 4.It is important to utilise this product according to its specified over-voltage category.

OPERATION DIAGRAM

Motor voltage 100%

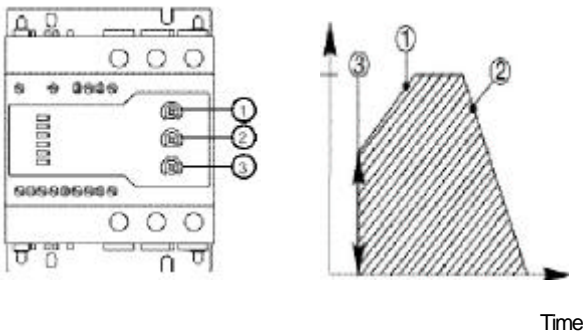

- 1 Ramp-up time** 1to 10s. Time from zero load voltage to full load voltage
- 2 Ramp-down time** 1 to 30s. Time from full load voltage to zero load voltage
- 3 Initial torque** 0 to 70% voltage at the start of the ramp-up function

WIRE SIZE

L1, T1 L2, T2 L3, T3		1 x 4... 25mm ² No. 12... 4AWG	 1,5... 2,5Nm
A1, A2 P1, P2 11, 21, 22		1 x 0,5... 25mm ² No. 18... 14AWG	 0,3... 2,5Nm

TROUBLESHOOTING GUIDE

Problem	Status Indication LED	Suggested Solution
Motor fails to start when...	POWER ON is OFF	Check power cable connections to L1, L2, L3. (Internal power supply is connected to L1,L2). Check also fuses, contactors and motor protection devices. Line voltage is too low-measure line voltage.
	POWER ON is ON	Check cable connections from T1, T2, T3 to motor terminals. Check control input connections to A1, A2. There is a delay of 0.5s (approx) until ramping starts, after applying control voltage.
	OVERHEAT is ON intermittently	Device has over-heated. Allow time to cool down. Check that number of starts per hour does not exceed specified level.
	OVER-HEAT is ON continuously	PTC alarm has occurred. If motor PTC is not connected, ensure that PTC terminals P1, P2 are connected to each other with a loop. If motor PTC is connected, motor may have over-heated. If motor has not over-heated, PTC sensor may be faulty .
	? LOSS is ON	Missing phase voltage. Check power cable connections to L3. If either L1 or L2 is missing, POWER ON and ? LOSS LEDs will be OFF.
	WRONG? is ON	Incorrect phase sequence. Change the terminal position of two of the power supply cables connected to L1, L2, L3.
Alarm activated	Any alarm LED is ON	After noting type of alarm, disconnect mains supply L1, L2, L3. Re-connect only if problem has been resolved. This resets device.



type / order-number

frenopact-2 S2522 / 220 V	60000341
S2540 / 400 V	60000338
S2548 / 480 V	60000339
S2560 / 600 V	60000340 *

control input

A1 / A2	24-550VAC/DC* 24-660VAC/DC
---------	-----------------------------------

power circuit

current AC	
bypass included	25 A
voltage / motorpower	
S2522	127...220 Veff (+-15%) / 5,5kW
S2540	230...400 Veff (+-15%) /11,0 kW
S2548	227...480 Veff (+-15%) /15,0 kW
S2560	346...600 Veff (+-15%) /18,5 kW

general specifications

rated AC frequency	50/60 Hz+-10%
ramp up time / down time	1-10s / 1-30s
initial torque	0-70%
auxiliary relays	
bypass relay activation	normally open (21,22)
over- temperature, phase sequence, phase loss alarm	normally closed (11,22)
max. size line conductors	25 mm ² stranded
max. size secondary conductors	2,5mm ²
operating temperature	-20°C bis + 60°C
storage temperature	-50°C bis + 85°C
approvals	UL, cUL, CSA(pending)
markings	CE
norms	IEC/EN 60 947-4-2

terminal diagram

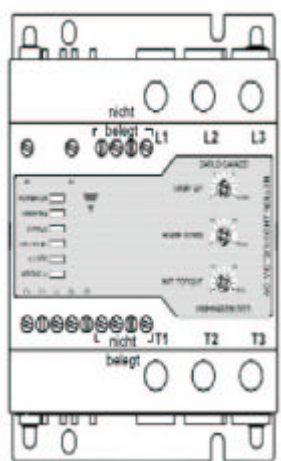

- A1, A2: control input
- 21, 22: bypass relay activation (normally open)
- 11, 22: alarms (normally closed)
- P1, P2: PTC-input or jumper

dimensions (mm)

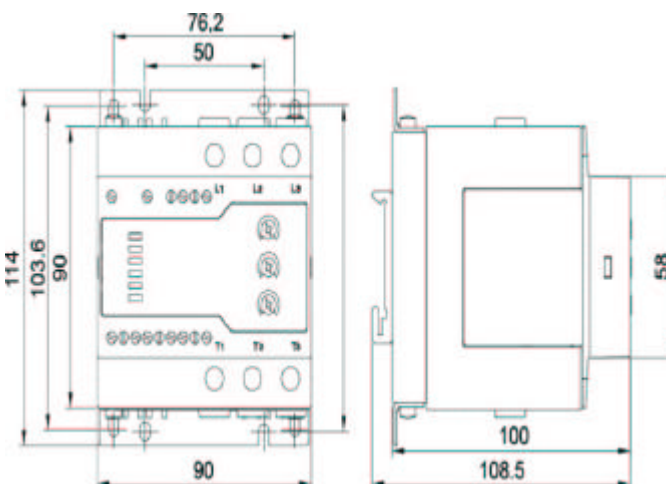

wiring diagram

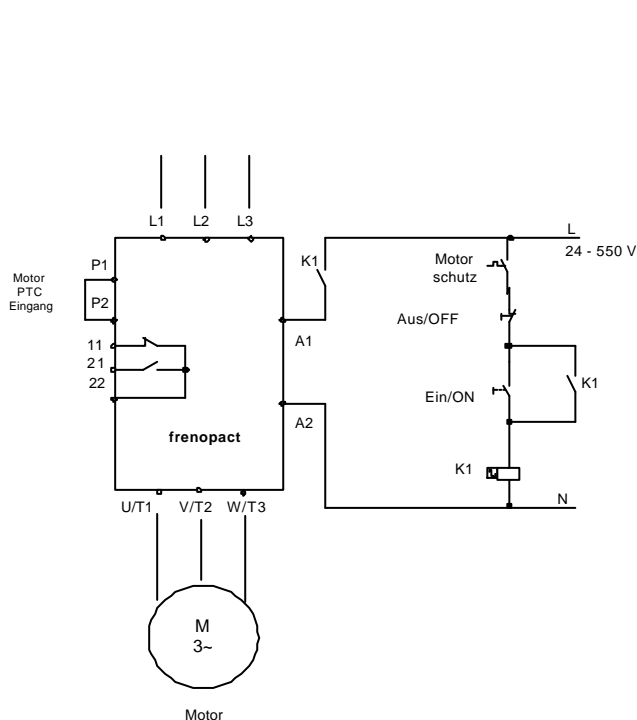

alternativ :

