

Summary from TT100 series inverter user's full manual

Power wiring connection

- In case of 3-phase input inverter, connect R/L1, S/L2 and T/L3 terminals with power source from network.
- In case of single-phase input inverter, connect L1/R and L2/S terminals with power source from network
- Connect PE/E to earthing
- Connect U, V and W terminals to motor cable
- Motor shall have to be ground connected. Electrified motor could cause interference
- Braking cell is built-in (standard only on three phase 400V version). If the load inertia is moderate, it is Ok to only connect braking resistance

Power terminals sketch of inverter with single-phase 230V 0.2~0.75kW.

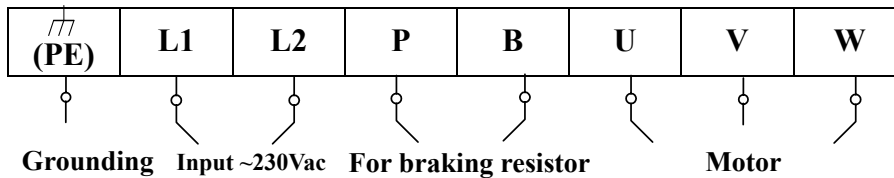

Power terminals sketch of inverter with single-phase 230V 1.5kW~2.2kW and three-phase 400V 0.75kW~15kW.

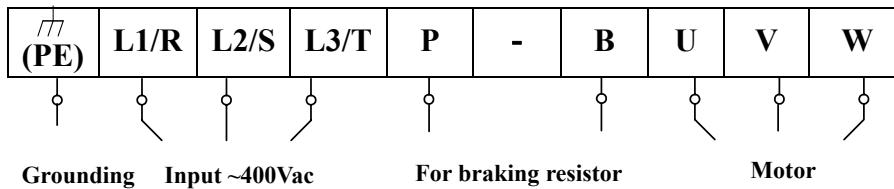

Note: power terminals L1/R, L2/S of single-phase 230V 1.5kW and 2.2kW are connected to 230V of power grid; L3/T is not connected.

The inverters below 11 kW have no the terminal “ - ”.

(The figure is only a sketch, terminals order of practical products may be different from the above-mentioned figure.)

Parameters Setting

If was set “password valid” (F107=1), user’s password must be entered first if parameters are to be set after power off or protection is effected. User’s password is invalid before delivery, and user could set corresponding parameters without entering password.

Steps for Parameters Setting

Steps	Keys	Operation	Display
1	Fun	Press “Fun” key to display function code. i.e F100	F100
2	▲ or ▼	Press “Up” or “Down” to select required function code	F14
3	Set	To read data set in the function code	5.0
4	▲ or ▼	To modify data	9.0
5	Set	To save new data and exit. Press “FUN” to show status data onto the display	
	Fun	Pressing once, show the parameter code, pressing again, it shows status data.	F14

The above-mentioned step should be operated when inverter is in stop status.

As parameters setting costs time due to numerous function codes, such function is specially designed as “Function Code Switchover in a Code Group or between Two Code-Groups” so that parameters setting becomes convenient and simple.

Press “Fun” key so that the keypad controller will display function code. If press “▲” or “▼” key then, function code will circularly keep increasing or decreasing by degrees within the group; if press the “stop/reset” key again (and DTG LED turns off), function code will change circularly between two code groups when operating the “▲” or “▼” key. I.e, pressing twice “▲”, F300 is selected. Press again the “stop/reset” key (LED DTG turns on) and parameters of the same group are selectable.

E.g. when function code shows F111 and DGT indicator is on, press “▲”/“▼” key, function code will keep increasing or decreasing by degrees within F100 ~ F160. Press “stop/reset” key again, DGT LED will be off. When pressing “▲”/“▼” key, function codes will change circularly among the 10 code-groups, like F211, F311...FA11, F111... Refer to Fig 1 (The sparkling “50.00” is indicated the corresponding target frequency values).

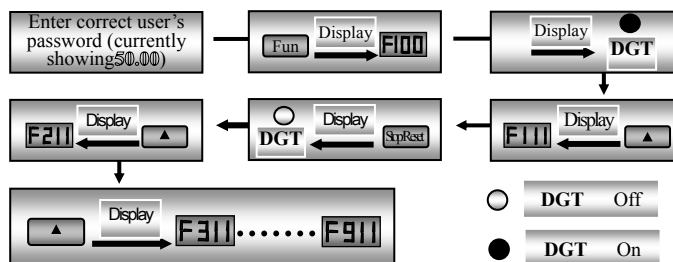

Fig 1 Switch over in a Code Group or between Different Code-Groups

Control terminals

TA	TB	TC	DO1	24V	CM	OP1	OP2	OP3	OP4	OP5	OP6	10V	AI1	AI2	GND	AO1	AO2
----	----	----	-----	-----	----	-----	-----	-----	-----	-----	-----	-----	-----	-----	-----	-----	-----

The way to operate the inverter is to use the control terminals correctly and flexibly. The control terminals are not operated separately, and they should match corresponding settings of parameters.

Functions of Control Terminals

Terminal	Type	Description	Function	
DO1	Output signal	Multifunctional output terminal 1	When the token function is valid, the value between this terminal and CM is 0V. When the inverter is stopped, the value is 24V.	The functions of output terminals shall be defined per manufacturer's value. Their initial state may be changed through changing function codes.
TA		Relay contact	TC is a common point, TB-TC are normally closed contacts, TA-TC are normally open contacts. The contact capacity is 10A/125Vac, 5A/250Vac, 5A/30Vdc.	
TB				
TC				
AO1	Running frequency	It is connected with frequency meter or speedometer externally, and its minus pole is connected with GND. See F423 ~ F426 for details.		
AO2	Current display	It is connected with ammeter externally, and its minus pole is connected with GND. See F427 ~ F430 for details		
10V	Analog power supply	Self contained power supply	Internal 10V self-contained power supply of the inverter provides power to the inverter. When used externally, it can only be used as the power supply for voltage control signal, with current restricted below 20mA.	
AI1	Input Signal	Voltage analog input port	When analog speed control is adopted, the voltage signal is input through this terminal. The range of voltage input is 0 ~ 10V, grounding: GND. When potentiometer speed control is adopted, this terminal is connected with center tap, earth wire to be connected to GND.	
AI2		Voltage / Current analog input port	When analog speed control is adopted, the voltage or current signal is input through this terminal. The range of voltage input is 0~5V or 0~10V and the current input is 0 ~ 20mA, input resistor is 500Ω. Grounding: GND. If the input is 4 ~ 20mA, it can be realized through adjusting parameter F406=2. The voltage or current signal can be chosen by coding switch. See manual for details, the current channel (0-20mA) is chosen before delivery.	
GND		Self-contained Power supply Ground	Ground terminal of external control signal (voltage control signal or current source control signal) is also the ground of 10V power supply of this inverter.	
24V	Power supply	Control power supply	Power: 24±1.5V, grounding: CM. Current is restricted below 50mA for external use.	
OP1	Digital input control terminal	Jogging terminal	When this terminal is in the valid state, the inverter will have jogging running. The jogging function of this terminal is valid under both at stopped and running status. This terminal can also be used as high-speed pulse input port. The max frequency is 50K.	The functions of input terminals shall be defined per manufacturer's value. Other functions can also

OP2		External Emergency Stop	When this terminal is in the valid state, "ESP" malfunction signal will be displayed.	be defined by changing function codes.
OP3		"FWD" Terminal	When this terminal is in the valid state, inverter will run forward.	
OP4		"REV" Terminal	When this terminal is in the valid state, inverter will run reversely.	
OP5		Reset terminal	Make this terminal valid under fault status to reset the inverter.	
OP6		Free-stop	Make this terminal valid during running, can realize free stop.	
CM	Common port	Grounding of control power supply	The grounding of 24V power supply and other control signals.	

Basic application diagrams

Illustration of inverter basic operation: we hereafter show various basic control operation processes by taking a 7.5kW inverter that drives a 7.5kW three-phase asynchronous AC motor as an example. The parameters indicated on the nameplate of the motor are as follows: 4 poles; rated power, 7.5KW; rated voltage, 400V; rated current, 15.4A; rated frequency 50.00HZ; and rated rotary speed, 1440rpm.

1) Operation processes of frequency setting, start, forward running and stop with keypad panel

(1) Connect the wires in accordance with Figure. After having checked the wiring successfully, switch on the air switch, and power on the inverter.

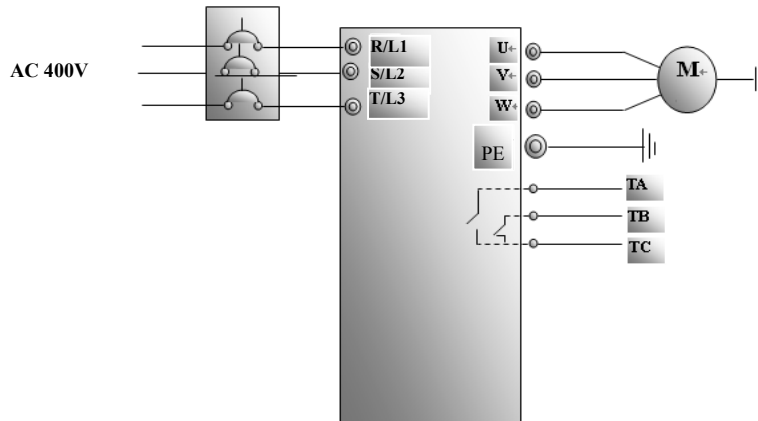

Wiring Diagram 1

- (2) Press the “Fun” key, to enter the programming menu.
- (3) Measure the parameters of motor stator resistance parameter
Enter F801 parameter and set rated power of the motor to 7.5kW;
Enter F802 parameter and set rated voltage of the motor to 400V;
Enter F803 parameter and set rated current of the motor to 15.4A;
Enter F804 parameter and set number of poles of the motor to 4;
Enter F805 parameter and set rated rotary speed of the motor to 1440 rpm;
Enter F800 parameter and set it to 1 to allow measuring the parameter of the motor
Press the “Run” key, to measure the parameters of the motor. After completion of the measurement, relevant parameters will be stored in F806. For the details of measurement of motor parameters, please refer to “Operation process of measuring the motor parameters” in this manual and Chapter XII of this manual.
- (4) Set functional parameters of the inverter:
Enter F203 parameter and set it to 0;
Enter F111 parameter and set the frequency to 50.00Hz;
Enter F200 parameter and set it to 0; select the mode of start as keypad control;
Enter F201 parameter and set it to 0; select the mode of stop as keypad control;
Enter F202 parameter and set it to 0; select forward locking.
Enter F208 parameter and set it to 0.
Enter F159 and select 0 or 1 depending which makes better silent the motor during running
- (5) Press the “Run” key, to start the inverter;
- (6) During running, current frequency of the inverter can be changed by pressing ▲ or ▼;
- (7) Press the “Stop/Reset” key once, the motor will decelerate until it stops running;
- (8) Switch off the air switch, and power off the inverter.

NOTE: STATUS data

During STOP time, pressing again and again “FUN” button, the display shows 4 status parameters cyclically: parameter code (i.e. F100) → rated speed of the motor (i.e. 1500 rpm) → DC bus voltage (i.e. 320 Vdc) → target frequency flashing (that is the frequency of running, soon after the inverter starts, i.e. 50.00 Hz) and again from beginning.

NOTE2: Valid digit

Inside parameters that are defined by a big number (i.e. F153 = carrier frequency) pressing the button “stop/reset” again and again, the scrolling digit becomes valid (that is the digit which can be modified by ▲ or ▼ buttons). This digit becomes flashing. Scrolling it, is possible to change also most significant digits but not the less significant digits.

2) Operation process of setting the frequency with keypad panel, and starting, forward and reverse running, and stopping inverter through control terminals

(1) Connect the wires in accordance with Figure. After having checked the wiring successfully, switch on the air switch, and power on the inverter;

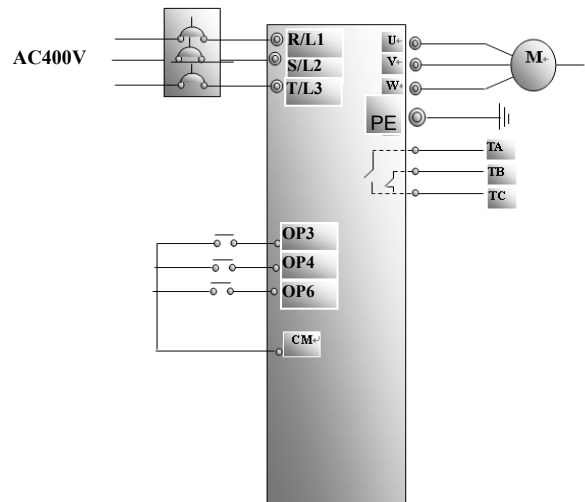

Wiring Diagram 2

- (2) Press the "Fun" key, to enter the programming menu.
- (3) Study the parameters of the motor: the operation process is the same as that of example 1.
- (4) Set functional parameters of the inverter:
 - Enter F203 parameter and set it to 0; select the mode of frequency setting to digital given memory;
 - Enter F111 parameter and set the frequency to 50.00Hz;
 - Enter F208 parameter and set it to 1; select two-line control mode 1 (Note: when F208 ≠ 0, F200, F201 and F202 will be invalid.)
 - Enter F159 and select 0 or 1 depending which makes better silent the motor during running
 - Check F318 = 15 (OP3 = forward running)
 - Check F319 = 16 (OP4 = reverse running)
- (5) Close the switch OP3, the inverter starts forward running;
- (6) During running, current frequency of the inverter can be changed by pressing ▲ or ▼;
- (7) During running, switch off the switch OP3, then close the switch OP4, the running direction of the motor will be changed (Note: The user should set the dead time of forward and reverse running F120 on the basis of the load. If it was too short, OC protection of the inverter may occur.)
- (8) Switch off the switches OP3 and OP4, the motor will decelerate until it stops running;
- (9) Switch off the air switch, and power off the inverter.

3) Operation process of setting the frequency with analog terminal and controlling the operation with control terminals

(1) Connect the wires in accordance with Figure. After having checked the wiring successfully, switch on the air switch, and power on the inverter. Note: 2K ~ 5K potentiometer may be adopted for setting external analog signals. For the cases with higher requirements for precision, please adopt precise multiturn potentiometer, and adopt shielded wire for the wire connection, with near end of the shielding layer grounded reliably.

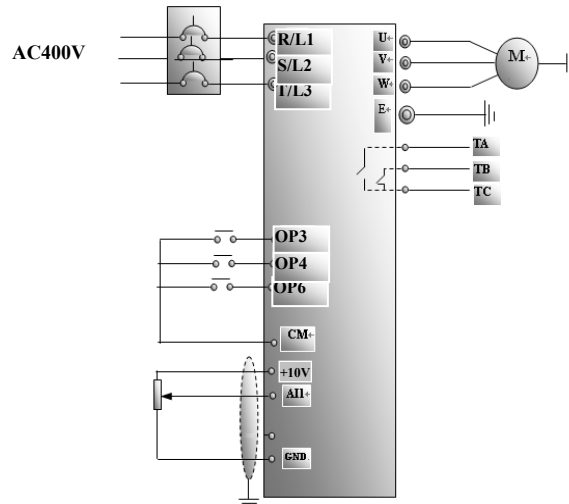

Wiring Diagram 3

- (2) Press the "Fun" key, to enter the programming menu.
- (3) Study the parameters of the motor: the operation process is the same as that of example 1.
- (4) Set functional parameters of the inverter:
 - Enter F203 parameter, and set it to 1; select the mode of frequency setting of analog AII, 0 ~ 10V voltage terminal;
 - Enter F208 parameter, and set it to 1;
 - Enter F159 and select 0 or 1 depending which make better silent the motor during running
 - Check F318 = 15 (OP3 = forward running)
 - Check F319 = 16 (OP4 = reverse running)
 - Check F321 = 8 (OP6 = emergency free stop), reset pressing the button "stop/reset"
- (5) Close the switch OP3, the motor starts forward running;
- (6) The potentiometer can be adjusted and set during running, and the current setting frequency of the inverter can be changed;
- (7) During running, switch off the switch OP3, then, close OP4, the running direction of the motor will be changed;
- (8) Switch off the switches OP3 and OP4, the motor will decelerate until it stops running;
- (9) Switch off the air switch, and power off the inverter.

Overall connection diagram

Note:

1. Please only connect power terminals L1/R and L2/S with power grid for single-phase inverters.
2. Remote-control panel and 485 communication port should be connected with 4 core telephone wire. They must not be used at the same time.

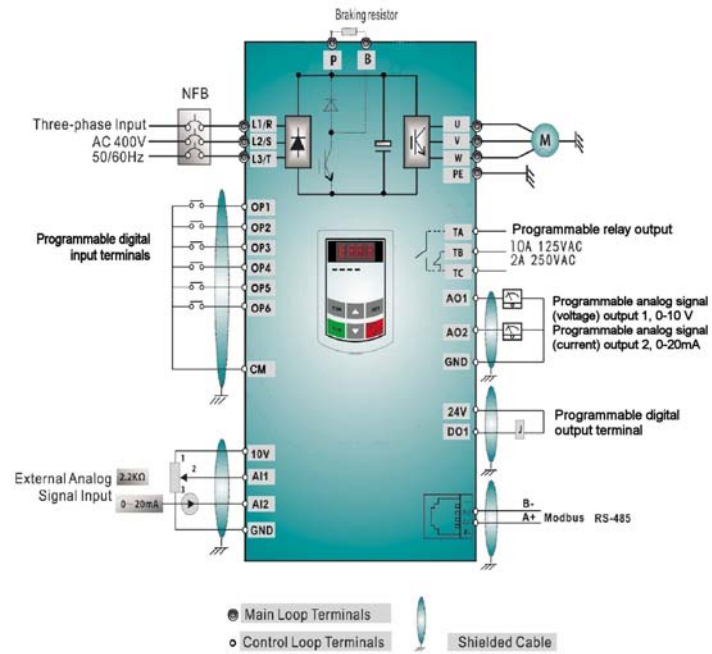

3. 485 communication port has built-in standard Modbus communication protocol. Communication port is on the left side of inverter. The sequence from top to down is 5V power, B-terminal, A+ terminal and GND terminal.
4. The contact capacity is 10A/125Vac, 5A/250Vac, 5A/30Vdc.